

### BRT-53X19A

**Description:** Rectangular, acrylic target  
**Reflectivity Factor:** 1.4  
**Max. Temperature:** -20° to +60° C

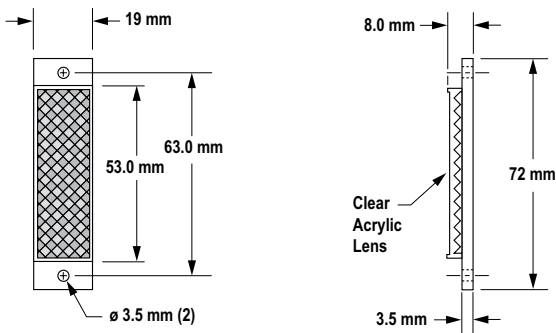

### BRT-60X40AF

**Description:** Rectangular, acrylic target  
**Reflectivity Factor:** 1.4 **Max. Temperature:** -20° to +60° C  
**Other:** Anti-fogging coating for use around steam. Optional brackets are available. See page 620.

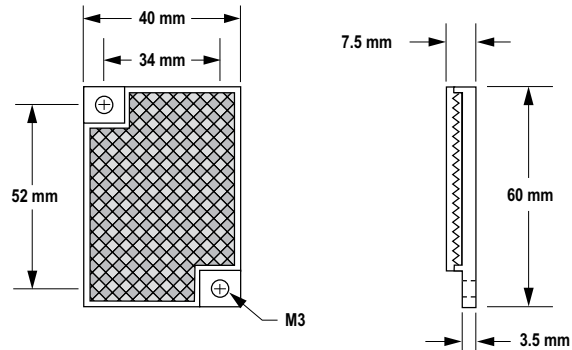

### BRT-60X40C

**Description:** Rectangular, acrylic target  
**Reflectivity Factor:** 1.4 **Max. Temperature:** -20° to +60° C  
**Other:** Optional brackets are available. See page 620.

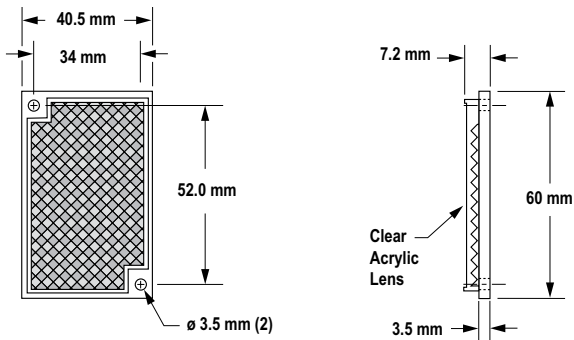

### BRT-60X40IP69K

**Description:** Rectangular, acrylic target (color is amber)  
**Reflectivity Factor:** 1.4 **Max. Temperature:** -20° to 140° C  
**Other:** Chemically resistant and IP69K washdown rated. Optional brackets are available. See page 620.

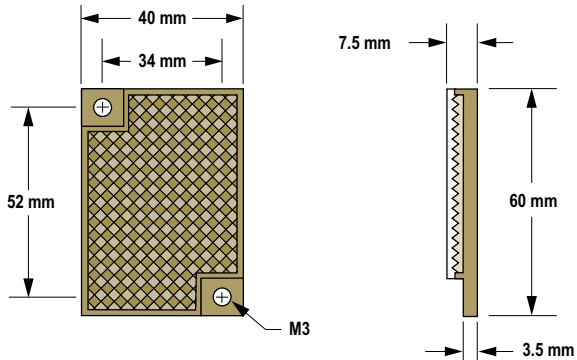

### BRT-62X10AM

**Description:** Rectangular, thin profile acrylic target  
**Reflectivity Factor:** 1.2  
**Max. Temperature:** -20° to +60° C  
**Other:** This target has micro-prism geometry.

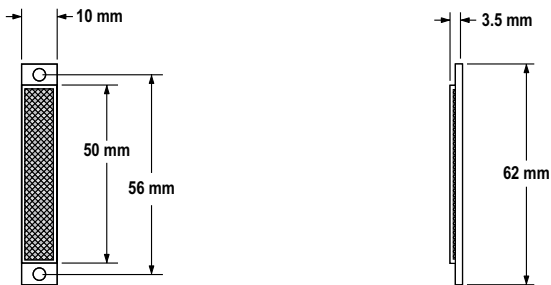

### BRT-80X50C

**Description:** Rectangular, acrylic target  
**Reflectivity Factor:** 1.4  
**Temperature:** -20° to +60° C

